

## STANDARD PAVEMENT SECTION

N.T.S.

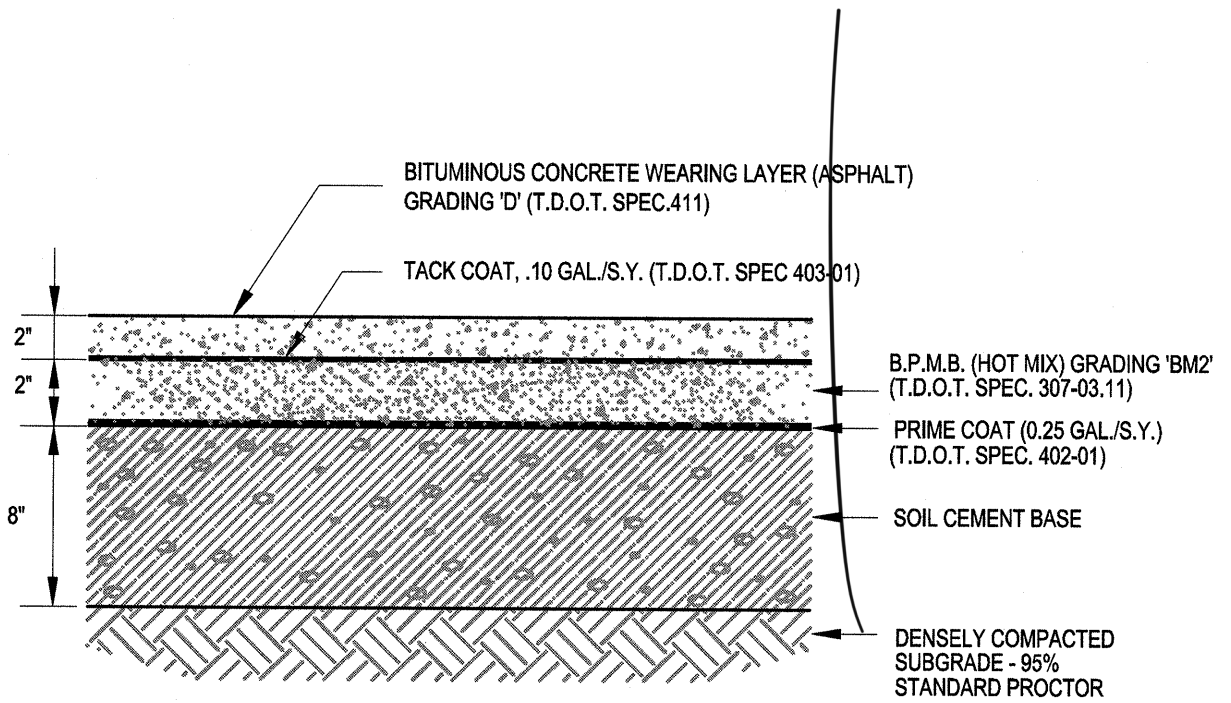

## HEAVY DUTY ASPHALTIC PAVEMENT

N.T.S.

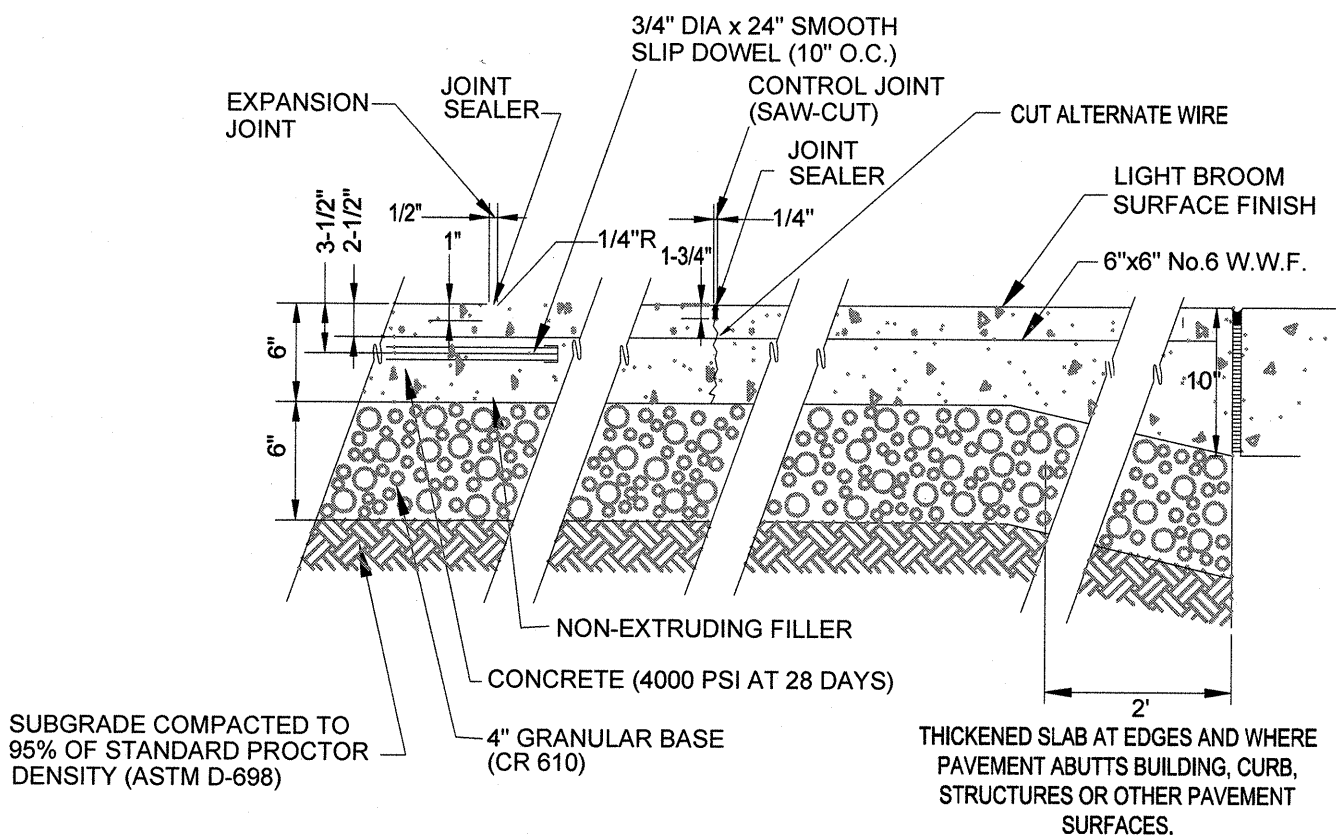

## CONCRETE PAVEMENT SECTION

NOT TO SCALE